

ANR-EP3KN1 Series

Networking 1U Rackmount

- *AMD EPYC™ 3000 SoC*
- *3x/4x Exp. NIMs*
- *1+1 Redundant PSU*

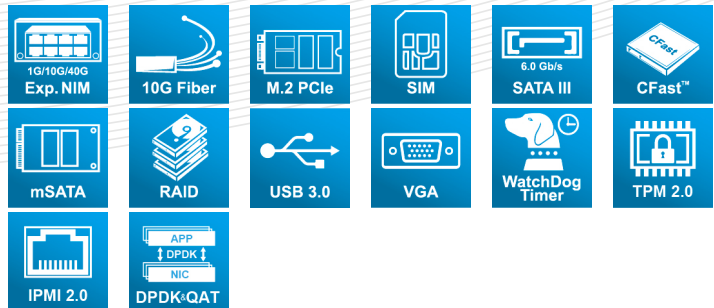

User Manual

Acrosser Technology Co., Ltd.
www.acrosser.com

Disclaimer

For the purpose of improving reliability, design and function, the information in this document is subject to change without prior notice and does not represent a commitment on the part of Acrosser Technology Co., Ltd.

In no event will Acrosser Technology Co., Ltd. be liable for direct, indirect, special, incidental, or consequential damages arising out of the use or inability to use the product or documentation, even if advised of the possibility of such damages.

Copyright

This document contains proprietary information protected by copyright. All rights are reserved. No part of this manual may be reproduced by any mechanical, electronic, or other means in any form without prior written permission of Acrosser Technology Co., Ltd.

Trademarks

The product names appear in this manual are for identification purpose only. The trademarks and product names or brand names appear in this manual are the property of their respective owners.

Purpose

This document is intended to provide the information about the features and use of the product.

Audience

The intended audiences are technical personnel, not for general audiences.

Ver: 100-003

Date: Sep. 29, 2020

To read this User Manual on your smart phone, you will have to install an APP that can read PDF file format first. Please find the APP you prefer from the APP Market.

Table of Contents

1. Introduction	5
1.1. Models	5
1.2. Specifications	5
1.3. Packing List	7
1.4. ANR-EP3KN1 Series Comparison Table	8
1.5. Layout & Dimension	9
1.6. Front Panel	10
1.7. Rear Panel	12
2. Components Assembly	13
2.1. Installation of Fixing Screws for M.2 SSD / Cfast / SIM Card	13
2.2. HDD Screws Assembly	14
2.3. Center HDD Bay Assembly	15
2.4. Side HDD Bay Assembly	16
2.5. PCI-E Add-on Card Assembly	18
2.6. NIM Module Insertion	21
2.7. Rack Installation	24
3. BIOS Settings	27
3.1. Main Setup	27
3.2. Advanced Setup	28
3.2.1. Advanced Setup: Trusted Computing	29
3.2.2. Advanced Setup: Hardware Monitor	29
3.2.3. Advanced Setup: Serial Port Console Redirection	30
3.2.4. Advanced Setup: USB Configuration	31
3.2.5. Advanced Setup: On Board PIC Configuration	31
3.2.6. Advanced Setup: Network Stack Configuration	32
3.2.7. Advanced Setup: SATA Configuration	32
3.3. Security Setup	33
3.4. Boot Setup	33
3.5. Save/Exit Setup	34
3.6. Event Logs Setup	35
3.7. Server Mgmt Setup	35

4. Software Installation and Programming Guide.....	36
4.1. Introduction.....	36
4.1.1. Environment.....	36
4.1.2. GPIO	36
4.1.3. Watchdog	36
4.1.4. LCD Control Module	36
4.1.5. Power Supply Unit	37
4.1.6. Chassis Opened.....	37
4.2. File Descriptions.....	37
4.2.1. GPIO/Watchdog/LCD Control Module.....	37
4.3. API List and Descriptions	38
4.3.1. GPIO	38
4.3.2. Watchdog	38
4.3.3. LCD Control Module.....	39
4.3.4. Power Supply Unit (PMBUS)	40
4.3.5. Pmbus Command Code Summary	41
4.3.6. Chassis Opened.....	45
4.3.7. Notes.....	45
5. FAQ	46
Q 1. Where can I find the serial number of this product?	46

1. Introduction

The ANR-EP3KN1 series is the next generation of rack mount equipment with AMD EPYC™ EMBEDDED 3000 for networking, providing high performance and cost effective solution in x86 embedded system.

The ANR-EP3KN1 series support LTE, M.2, SATAIII and up to 4 of expansion NIMs with 1G/10G/40G networking ability.

1.1. Models

This manual is applied to the following models:

1. ANR-EP3KN1-16
2. ANR-EP3KN1-12
3. ANR-EP3KN1-08
4. ANR-EP3KN1-04

1.2. Specifications

System

Thermal Solution	<ul style="list-style-type: none"> • 3x System Smart Fan
SoC	<ul style="list-style-type: none"> • AMD Snowy Owl EPYC™ 3451, 16 cores • AMD Snowy Owl EPYC™ 3351, 12 cores • AMD Snowy Owl EPYC™ 3251, 8 cores • AMD Snowy Owl EPYC™ 3151, 4 cores
System Memory	<ul style="list-style-type: none"> • ANR-EP3KN1-16/12: 8x U-DIMM DDR4-2666 (ECC/non-ECC) • ANR-EP3KN1-08/04: 4x U-DIMM DDR4-2666 (ECC/non-ECC)
BIOS	<ul style="list-style-type: none"> • Support Console Re-direction • Support PXE Boot
VGA Chipset	<ul style="list-style-type: none"> • ASPEED® AST2510 (VGA only)

System Memory Channel A/B/C/D Support Table

	A0 / B0 / C0 / D0	A1 / B1 / C1 / D1
Not Support	Stuffed	
Support		Stuffed
support	Stuffed	Stuffed

Max. Frequency Support table				
DIMMs Populated per Channel	1R	2R, 2DR	Freq. (MT/s)	Notes on DDR4 UDIMM format:
1	1	-	2667	• 1R: 1 package rank of SDP DRAMs
	-	1	2400	
2	2	-	2133	• 2R: 2 package ranks of SDP DRAMs • 2DR: 2 package ranks of DDP DRAMs
	1	1	1866	
	-	2	1866	

Network Interface

- Ethernet (on-board)**
- 1x RJ-45 Copper
 - 1x GbE LAN (by I210-AT)

Storage

- SATA**
- 1x SATAIII socket or 1x CFast socket, selected by jumper setting
 - 1x SATAIII socket or 1x mSATA socket (Full-size support), selected by jumper setting
 - 2x SATAIII socket (**For ANR-EP3KN1-16/12 only**)
- HDD Bay**
- 2 x 2.5" Internal HDD Bay for **ANR-EP3KN1-04/08**
 - 4 x 2.5" Internal HDD Bay for **ANR-EP3KN1-12/16**
- M.2**
- (For ANR-EP3KN1-16/12 only)**
- 2x M.2 M-Key (PCIe[4X] & SATA signal)
(Type 22110, Type 2280, Type 2260 support)

Expansion I/O

- PCIe Slot**
- 1x PCIe Gen3 [16X] Slot ([8X] signal via CPU)
- Mini PCIe socket**
- (For ANR-EP3KN1-16/12 only)**
- 1x Mini PCIe socket (Full-size support)

Others

- Watchdog Timer**
- Software Programmable 0 ~ 255 Secs.
- Battery**
- Lithium Battery, 3V 220mAH (CR2032)
- Hardware Monitoring**
- CPU Voltage
 - CPU & SYS Temperature
 - SYS FAN Speed
- Security & Mgmt.**
- On-board TPM 2.0
 - Chassis Intrusion Detection (default: Disable)

OS support	<ul style="list-style-type: none"> • Linux Kernel 4.4 or above, (64-bit) • DPDK for ANR-EP3KN1 series
-------------------	---

Mechanical & Environment

Chassis Dimension	• 440 (W) x 44 (H) x 550 (D) mm
Operating Temperature	• 0 ~ 40°C (32 ~ 104°F)
Storage Temperature	• -20 ~ 80°C (-4 ~ 176°F)
Relative Humidity	• 0 ~ 85% @40°C, non-condensing
Power Supply Unit	<ul style="list-style-type: none"> • 1+1 Redundant ATX PSU • Single ATX PSU
Power Requirements	• ATX Circuit as AT Mode with Power Switch

EMC & Safety

Certification	• CE, FCC Class A, RoHS 2, cULus
Vibration Test	• IEC 60068-2-64, 5~500Hz, 3GRMS
Drop Test	• ISTA-2A 2006

1.3. Packing List

Check if the following items are included in the package.

	Item	Q'ty
<input type="checkbox"/>	ANR-EP3KN1 Series System	1
<input type="checkbox"/>	CD Utility	1
<input type="checkbox"/>	SATAIII Cable (04/08: 2pcs, 12/16: 4pcs)	2/4
<input type="checkbox"/>	RJ45-console cable (RJ45 <-> DB9)	1
<input type="checkbox"/>	USB-console cable (Micro-B <-> Type A)	1
<input type="checkbox"/>	Power Cord	2
<input type="checkbox"/>	Rack Bracket	2
<input type="checkbox"/>	Box Packing	1
<input type="checkbox"/>	Screw Pack	1
<input type="checkbox"/>	Slide Rail	1

1.4. ANR-EP3KN1 Series Comparison Table

Model Name	Model Parts Difference	Remark
ANR-EP3KN1-16	Epyc™ 16 cores solution / BMC: VGA only / PSU : RPSU	
ANR-EP3KN1-12	Epyc™ 12 cores solution / BMC: VGA only / PSU : RPSU	
ANR-EP3KN1-08	Epyc™ 08 cores solution / BMC: VGA only / PSU : Single PSU	
ANR-EP3KN1-04	Epyc™ 04 cores solution / BMC: VGA only / PSU : Single PSU	

1.5. Layout & Dimension

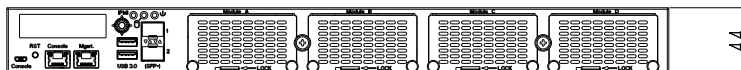
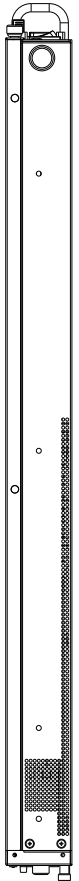
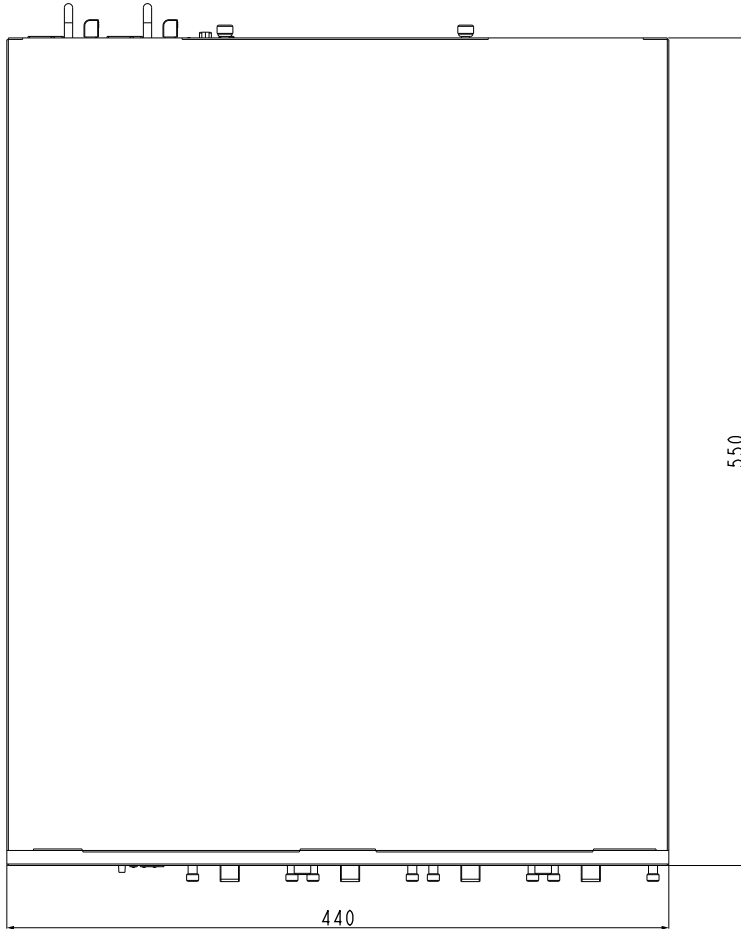
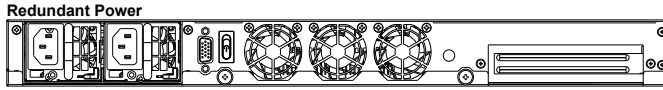
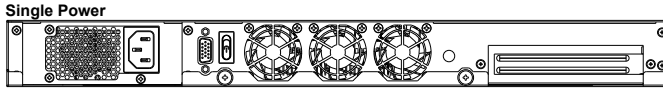

1.6. Front Panel

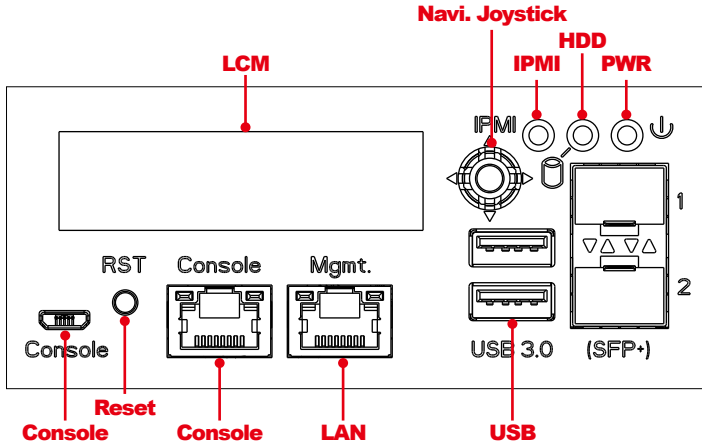
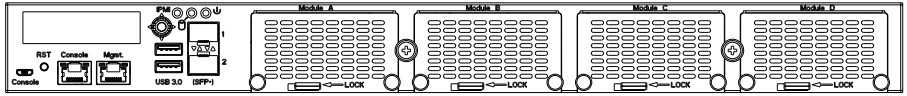

- **LCM Display**
128 * 32 Pixels Graphic mode only
- **Navigation Joystick**
LCM menu control buttons (Up/Down/Left/Right/Center)
- **IPMI**
IPMI indicator (Green)
- **HDD**
HDD activity indicator (Yellow)
- **PWR**
Power indicator (Green)
- **Console (Micro USB)**
Micro USB For Console Function

Note: Either Micro USB or RJ45 console can only be used one at a time.

- **RST**
System Reset Button

- **Console (RJ45)**

Standard Yost RJ45 Console port

	Pin #	Signal	Pin #	Signal
	1	RTS	5	GND
	2	DTR	6	RxD
	3	TxD	7	DSR
	4	GND	8	CTS

- **LAN**

Standard IEEE802.3 RJ45 connector for GbE

	LED		10	100	1000
	Left	Link	Green	Green	Green
		Active	Blinking	Blinking	Blinking
	Right	Speed	OFF	Yellow	Green

- **USB**

Standard USB 3.0 Type-A connector

- **SFP+ 10GbE LAN Ports**

	LED		1G	10G
	Left	Link	Green	Green
		Active	Blinking	Blinking
	Right	Speed	OFF	Blue

- **Module A ~ D**

Network expansion module connector

Note: NIMA supports PCIE Gen.3 up to x4 bandwidth.

1.7. Rear Panel

Single Power



Redundant Power

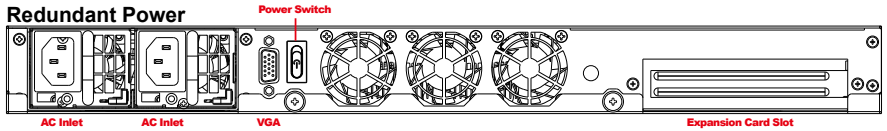

- **AC Inlet**
1U Redundant ATX PSU
- **VGA**
VGA connector
- **Power Switch**
Power on/off switch
- **Expansion Card Slot**
1x PCI express card insert slot

2. Components Assembly

Please follow the instruction to install the inner modules.

The products shown in the procedure are used for illustration only, may not reflect the exact outlooks.

2.1. Installation of Fixing Screws for M.2 SSD / Cfast / SIM Card

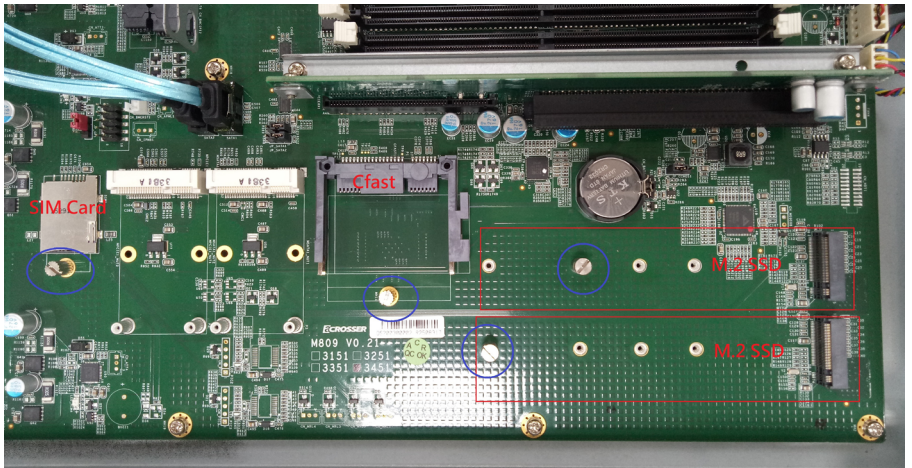

- Step 1: Before installing M.2 SSD / Cfast / SIM card, unscrew the handscrews as circled in blue as shown in the photo above.
- Step 2: After installed M.2 SSD / Cfast / SIM card, fix the handscrews at the nearest holes close to the card edge.

2.2. HDD Screws Assembly

Step 1: Prepare the screw pack. There should be 8 screws in the pack.

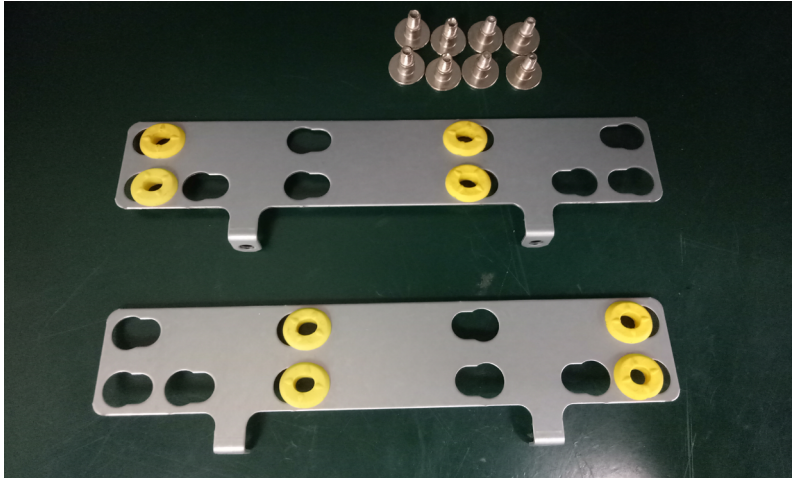

Step 2: Mount the anti-vibration rubber ring as shown. Push the rubber ring sideward. Do not leave the rubber ring inward.

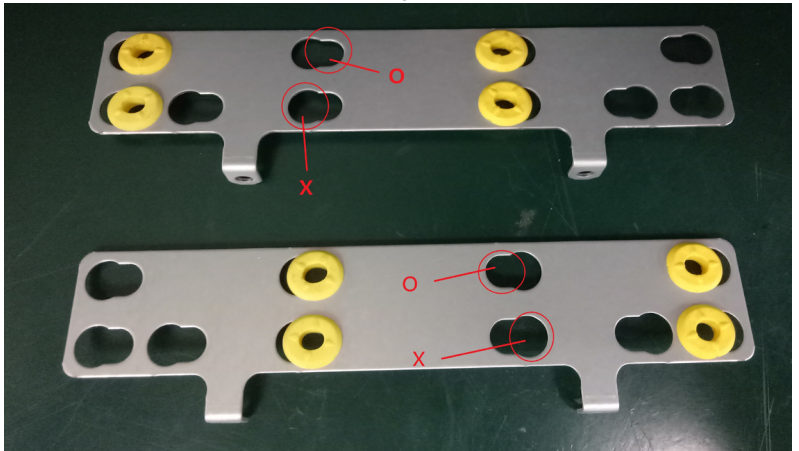

2.3. Center HDD Bay Assembly

Step 1: As shown below, install your HDD with screws into the bracket.

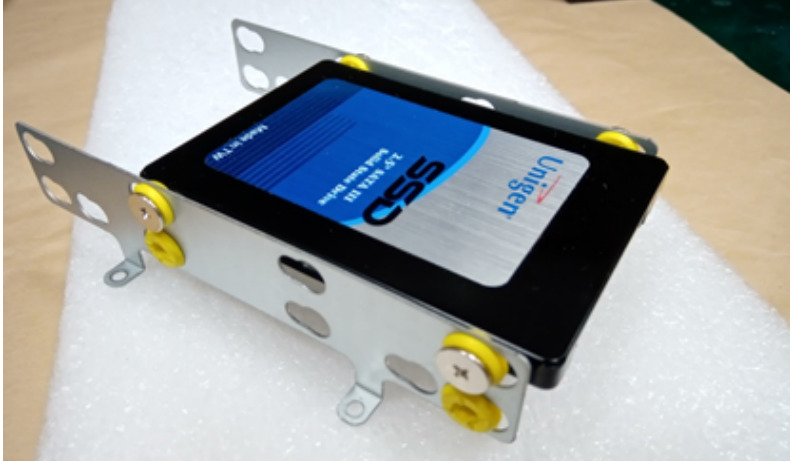

Step 2: Plug in the SATA1, SATA2 cable, & HDD power connector.



Step 3: Fix the HDD+bracket with screws onto the PCB.



2.4. Side HDD Bay Assembly

Step 1: As shown below, install your HDD with screws into the bracket.

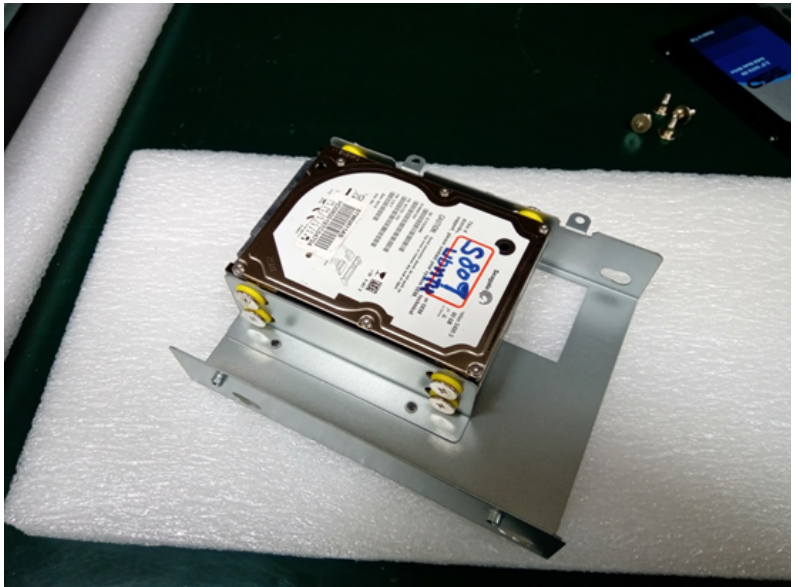

- Step 2: Plug in the SATA3, SATA4 cable, & HDD power connector. Fix the HDD+bracket with screws onto the chassis and PCB.



2.5. PCI-E Add-on Card Assembly

Step 1: Remove the PCI-E rear housing.

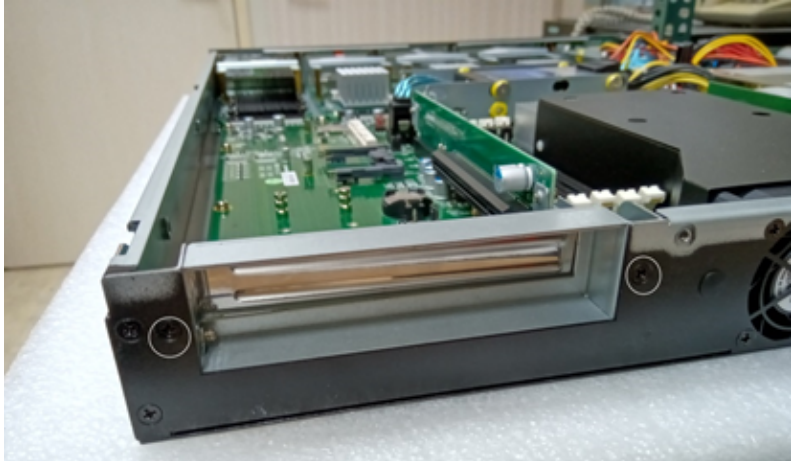

Step 2: Remove the housing.



Step 3: Remove the PCI-E riser set.



Step 4: Insert the PCI-E card together with riser card and housing set.

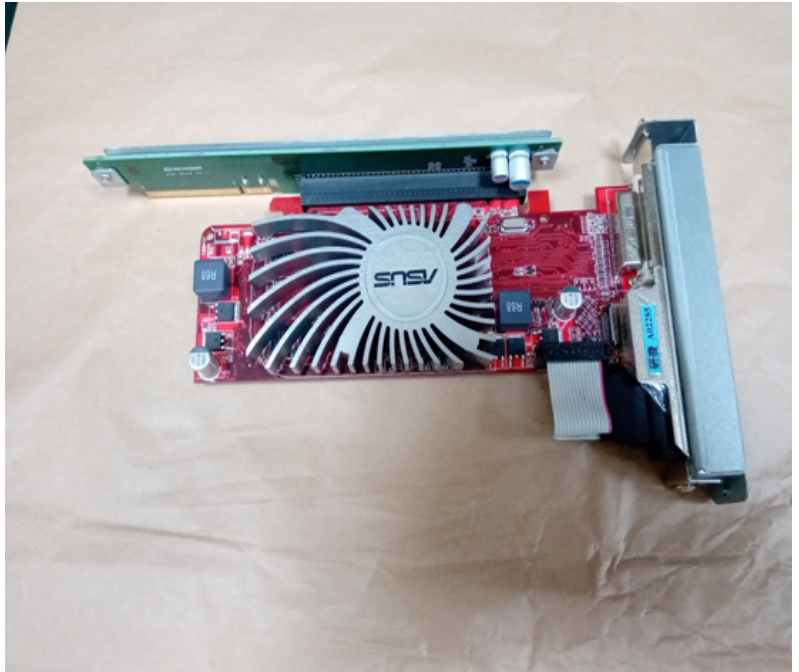

Step 5: Install the PCI-E riser set into the slot and fix to the rear housing.



2.6. NIM Module Insertion

To install the NIM module into the system:

Step 1: Remove the screw that lock the dummy cover on **Module A** slot.



Step 2: Open the dummy cover.



- Step 3: Insert your NIM module into the **Module A** slot. Firmly push it all the way in.



- Step 4: Push the latch left. This will lock the module.



Step 5: Use your fingers to lock back the screw.



Or you may use a screw driver to lock back the screw.



2.7. Rack Installation

Step 1: Pull out each inner bracket from the slide-rail kits until it locks in the extended position. Push the slide-rail lock to release the inner bracket from the mounting bracket. Do the same to the other bracket.

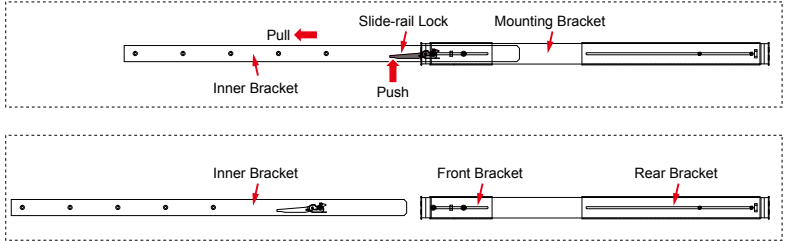

Step 2: Secure both left and right 1U mounting ears to the server's front panel chassis with your Phillips screwdriver.



- Step 3: Secure both left and right inner brackets by screws to each of the server's left and right side with your Phillips screwdriver.



- Step 4: Determine which rack hole numbers to use.
(a) If your rack has threaded mounting holes in the rack posts, determine whether the threads are metric or standard. Select the appropriate screws from the package included in the mounting kit.
(b) If your rack does not have threaded mounting holes, the mounting screws are secured with caged nuts.
- Step 5: Loosely attach the front slide-rail to the front right rack-post using two screws into the upper and lower holes. Do not tighten the screws yet.
- Step 6: Adjust the length of the slide-rail by sliding the rear bracket flange to reach the outside edge of the rear rack-post. Loosely attach the rear bracket to the rear right rack-post with two screws.
- Step 7: Attach the second slide-rail to the left rack-post in a similar manner. Again, do not tighten the screws.

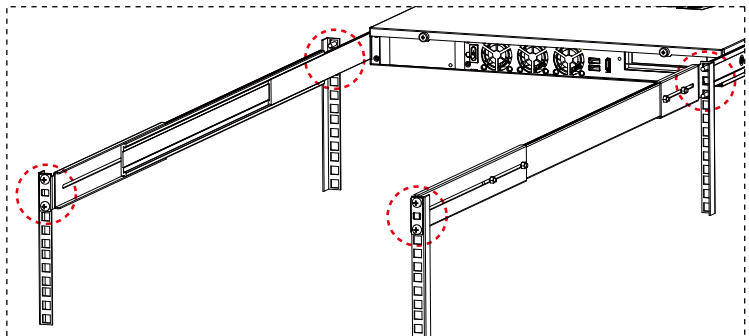

- Step 8: Fully extend the front and rear brackets to where it reaches the rack-post. Now tighten the screws to lock the ends of the rails in place with your Phillips screwdriver.

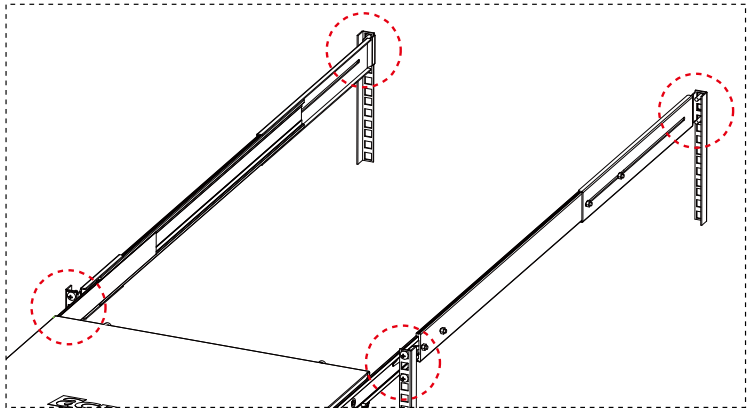

- Step 9: Tighten the four screws that fasten each of the front and rear brackets with your 6-point hex wrench.

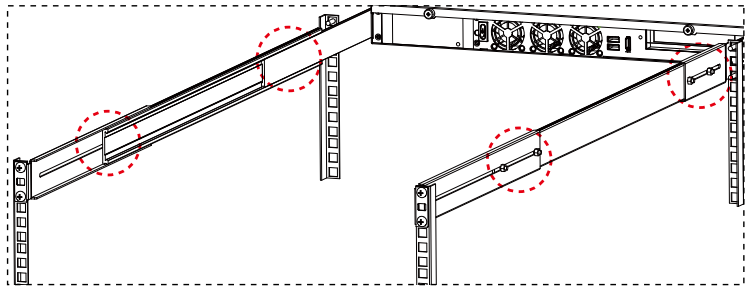

- Step 10: Slide the chassis all the way into the rack until the chassis mounting ears are against the front posts. Tighten the chassis mounting ears to the rack posts each by using one screw into the middle hole.



3. BIOS Settings

This chapter describes the BIOS menu displays and explains how to perform common tasks needed to get the system up and running. It also gives detailed explanation of the elements found in each of the BIOS menus. The following topics are covered:

- Main Setup
- Advanced Setup
- Security Setup
- Boot Setup
- Save/Exit Setup
- Event Logs Setup
- Server Mgmt Setup

Once you enter the Award BIOS™ CMOS Setup Utility, the Main Menu will appear on the screen. Use the arrow keys to highlight the item and then use the <Pg Up> <Pg Dn> keys to select the value you want in each item.

3.1. Main Setup

The BIOS setup main menu includes some options. Use the [Up/Down] arrow key to highlight the option, and then press the <Enter> key to select the item and configure the functions.



Note: Listed at the bottom of the menu are the control keys. If you need any help with the item fields, you can press <F1> key, and it will display the relevant information.

- **System Date**
Set the system date.
- **System Time**
Set the system time.

3.2. Advanced Setup

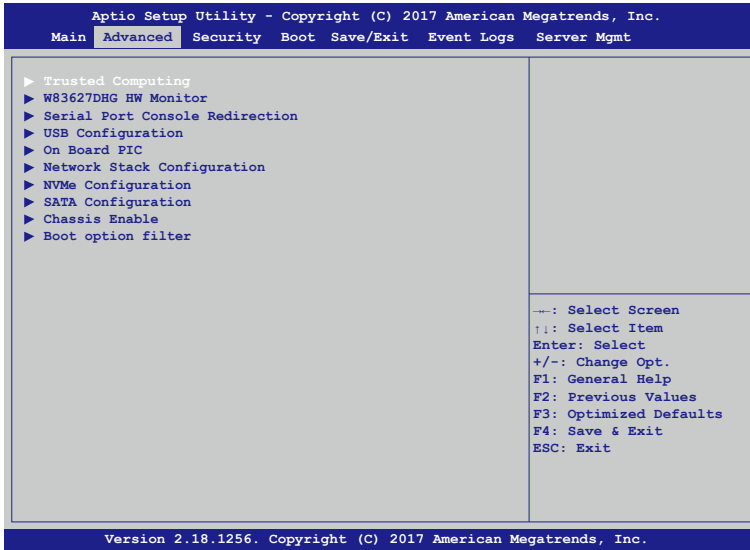

- **Trusted Computing**
Trusted computing settings.
- **W83627DHG HW Monitor**
Monitor hardware status.
- **Serial Port Console Redirection**
Console port Setting
- **Chassis Enable**
Chassis function enable/disable.
- **Boot option filter**
Chose boot to UEFI/Legacy OS.

3.2.1. Advanced Setup: Trusted Computing

Aptio Setup Utility - Copyright (C) 2017 American Megatrends, Inc.	
Advanced	
TPM20 Device Found Vendor: IFX Firmware Version: 5.63 Security Device Support [Enabled] Active PCR banks SHA-1, SHA256 Available PCR banks SHA-1, SHA256 TPM2.0 Clear Operation [None]	Enables or Disables BIOS support for security device. O.S. will not show Security Device. TCG EFI protocol and INT1A interface will not be available.
---: Select Screen ↑↓: Select Item Enter: Select +/-: Change Opt. F1: General Help F2: Previous Values F3: Optimized Defaults F4: Save & Exit ESC: Exit	
Version 2.18.1256. Copyright (C) 2017 American Megatrends, Inc.	

3.2.2. Advanced Setup: Hardware Monitor

Aptio Setup Utility - Copyright (C) 2017 American Megatrends, Inc.	
Advanced	
PC Health Status Smart Fan Function [Enabled] System temperature : +32°C Fan1 Speed : 6000 RPM Fan3 Speed : 6000 RPM VDDMEM : 0.992V V1P05A_PCH : +3.136V +5V : +3.136V +12V : +3.136V VCCP : +3.136V 3.3V : +3.136V	Enable or Disable Smart Fan
---: Select Screen ↑↓: Select Item Enter: Select +/-: Change Opt. F1: General Help F2: Previous Values F3: Optimized Defaults F4: Save & Exit ESC: Exit	
Version 2.18.1256. Copyright (C) 2017 American Megatrends, Inc.	

3.2.3. Advanced Setup: Serial Port Console Redirection

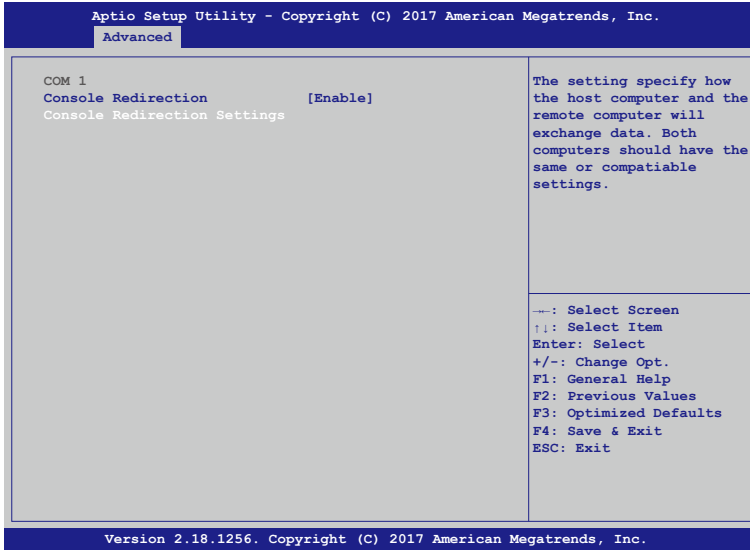

Note: Both the console function of RJ45 and micro USB will be disabled if the Console Redirection is set disabled.

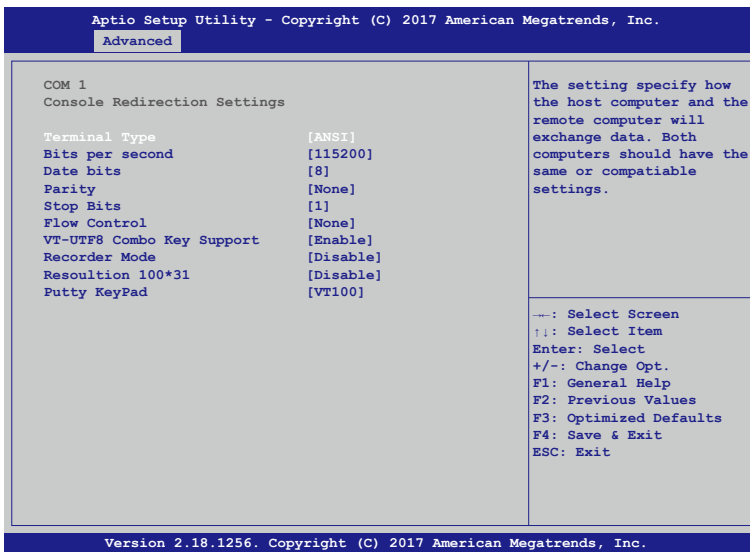

3.2.4. Advanced Setup: USB Configuration

Aptio Setup Utility - Copyright (C) 2017 American Megatrends, Inc.		
Advanced		
USB Configuration		Enables Legacy USB support. AUTO option disables legacy support if no USB devices are connected. DISABLE option will keep USB devices available only for EFI applications.
USB Module Version	19	
USB Controllers :		
USB Devices:		
Legacy USB Support	[Enabled]	
XHCI Hand-off	[Enabled]	
		--: Select Screen ↑↓: Select Item Enter: Select +/-: Change Opt. F1: General Help F2: Previous Values F3: Optimized Defaults F4: Save & Exit ESC: Exit
Version 2.18.1256. Copyright (C) 2017 American Megatrends, Inc.		

3.2.5. Advanced Setup: On Board PIC Configuration

Aptio Setup Utility - Copyright (C) 2017 American Megatrends, Inc.		
Advanced		
On Board PIC		On board PIC information
PIC name:	EP3KN1	
PIC Version:	010-003	
		--: Select Screen ↑↓: Select Item Enter: Select +/-: Change Opt. F1: General Help F2: Previous Values F3: Optimized Defaults F4: Save & Exit ESC: Exit
Version 2.18.1256. Copyright (C) 2017 American Megatrends, Inc.		

3.2.6. Advanced Setup: Network Stack Configuration

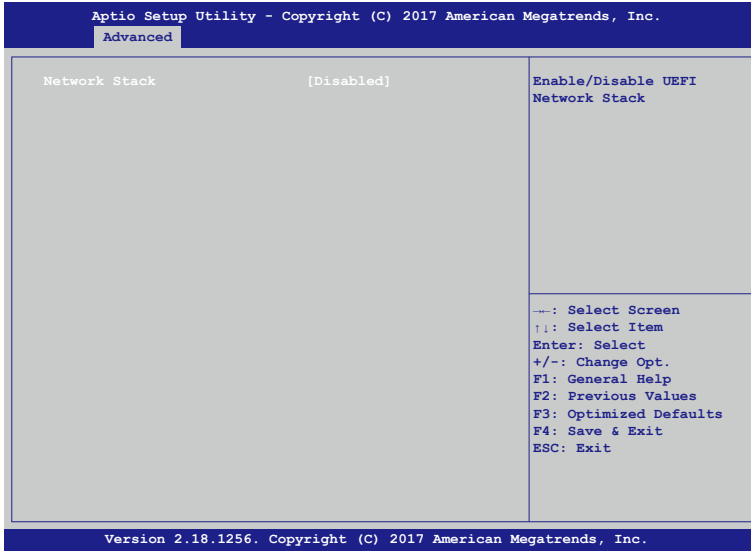

- **Network Stack**
Enable/Disable UEFI Network Stack

3.2.7. Advanced Setup: SATA Configuration

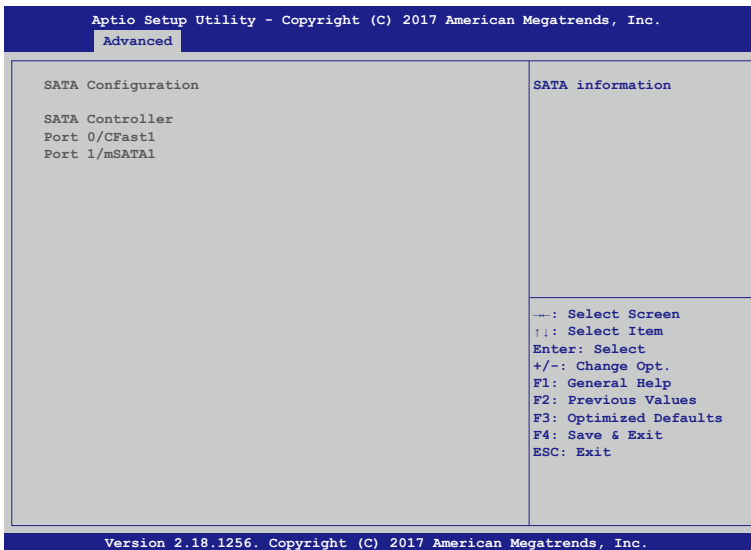

3.3. Security Setup

```
Aptio Setup Utility - Copyright (C) 2017 American Megatrends, Inc.
Main Advanced Security Boot Save/Exit Event Logs Server Mgmt

Password Description
If Only the Administrator's password is set,
then this only limits access to Setup and is
only asked for when entering Setup.

The password length must be
in the following rage:
Minimum length           3
Maximum length          20

Administrator Password

Set Administrator
Password

---: Select Screen
↑↓: Select Item
Enter: Select
+/-: Change Opt.
F1: General Help
F2: Previous Values
F3: Optimized Defaults
F4: Save & Exit
ESC: Exit

Version 2.18.1256. Copyright (C) 2017 American Megatrends, Inc.
```

- **Administrator Password**
Set Administrator Password.

3.4. Boot Setup

```
Aptio Setup Utility - Copyright (C) 2017 American Megatrends, Inc.
Main Advanced Security Boot Save/Exit Event Logs Server Mgmt

Boot Logo [Enabled]
Launch PXE OpROM Policy [Disabled]

Enables or disabled Quiet
Boot option

Boot Option Priorities
Network Device BBS Priorities

---: Select Screen
↑↓: Select Item
Enter: Select
+/-: Change Opt.
F1: General Help
F2: Previous Values
F3: Optimized Defaults
F4: Save & Exit
ESC: Exit

Version 2.18.1256. Copyright (C) 2017 American Megatrends, Inc.
```

- **Boot Logo**
[Enables or disables BOOT LOGO option.]
- **Launch PXE OpROM policy**
Pxe Enable/Disable.

3.5. Save/Exit Setup

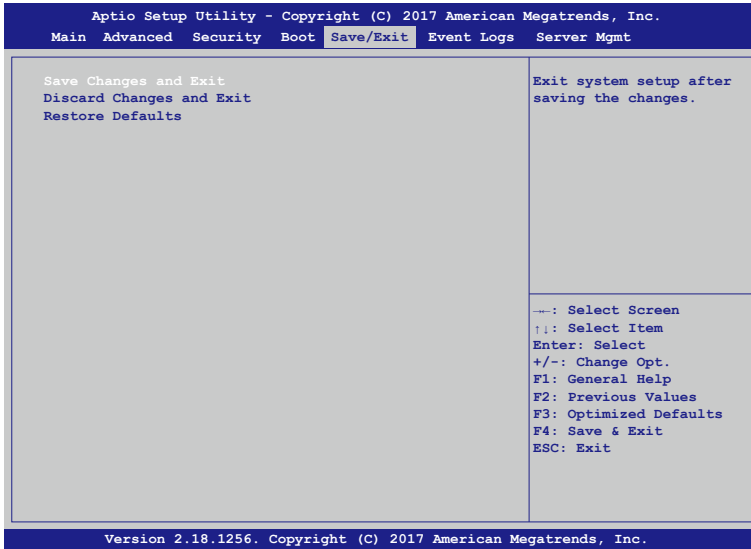

- **Save Changes and Exit**
Reset the system after saving the changes.
- **Discard Changes and Exit**
Reset the system without saving any the changes.
- **Restore Defaults**
Restore/Load Default values for all the setup options.

3.6. Event Logs Setup

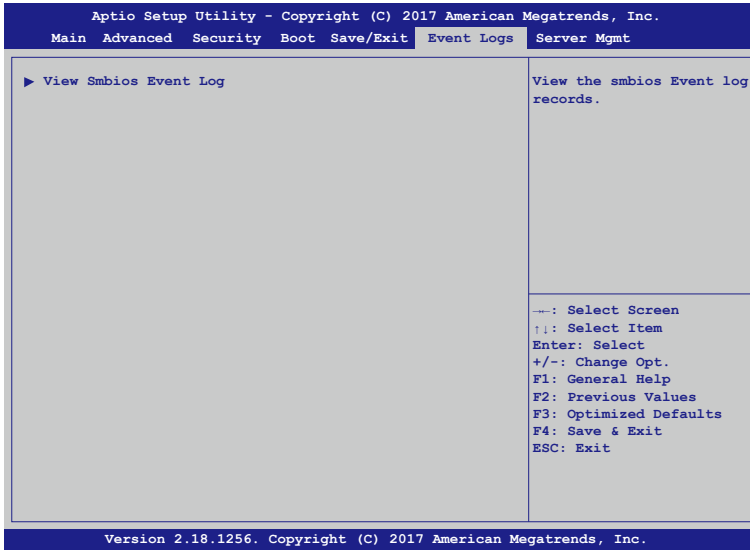

3.7. Server Mgmt Setup

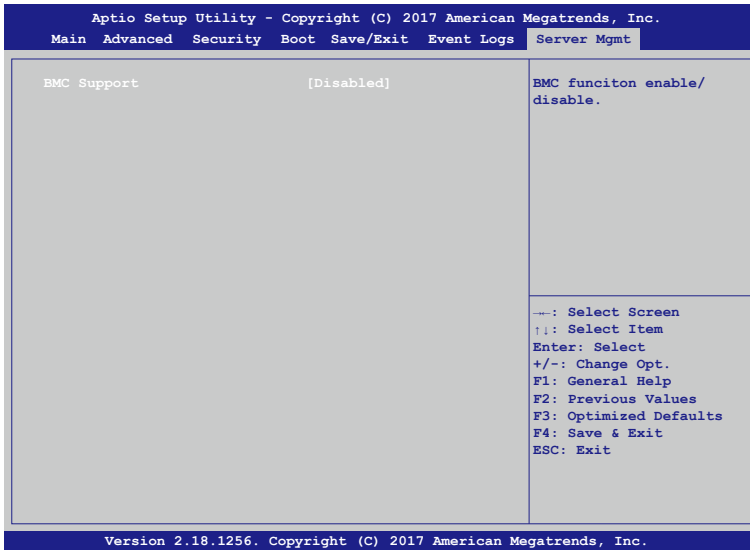

- **BMC Support**
 BMC function enable/disable.

4. Software Installation and Programming Guide

4.1. Introduction

4.1.1. Environment

This test utility develop based on kernel 4.4 above (Ubuntu 18.04.1 Desktop).

4.1.2. GPIO

The EP3KN1 provides GPIO interface. Users can use the GPIO APIs to Control GPO Pin.

4.1.3. Watchdog

The EP3KN1 provides a Watchdog timer. Users can use the Watchdog APIs to configure and to access the Watchdog timer. The Watchdog timer can be set to 1~255 seconds. Setting the timer to zero disables the timer. The remaining seconds of the timer to reboot can be read from the timer.

4.1.4. LCD Control Module

The LCM (short for LCD Control Module) APIs provide interfaces to control the module. By invoking these APIs, programmers can implement the applications which have the functions listed below:

1. Clear LCM screen.
2. Turn on or off the cursor on the screen.
3. Get the identification of the pressed key of the LCM.
4. Get LCM PIC Version.
5. Get the LCM mode.
6. Graphic write on LCM.

4.1.5. Power Supply Unit

The Power supply APIs provide pmbus to control the module. By invoking these APIs, programmers can implement the applications which have the functions listed below:

Pmbus:

1. Read vout 12v.
2. Read vout 3.3v.
3. Read vout 5v.
4. Get power supply unit status.

4.1.6. Chassis Opened

The chassis APIs provide control to the module. By invoking these APIs, programmers can implement the applications which have the functions listed below.

1. Get chassis opened status.
2. Set chassis opened (Enabled or Disabled).

4.2. File Descriptions

4.2.1. GPIO/Watchdog/LCD Control Module

1. TestUtility

The GPIO, Watchdog, Power Supply Unit, LCM Control Module, and chassis open. Console user interface bin binary.

2. Libw83627.h

This file includes the declarations of the APIs and macro definitions.

3. Libw83627.a

The static library for linux.

4. Libw83627.so

The dynamic library for linux.

5. Install_driver

This file is linux shell script file. Run this file can help you install environment and modprobe driver on linux.

6. readme

Use this utility first. Please read the readme file first.

4.3. API List and Descriptions

4.3.1. GPIO

Syntax:	Get_gpi_status(int pin)
Description:	Get the status of GPIO input pins status.
Parameters:	This function fills in an integer variable as the parameter. The pin0 ~ pin3 is the status of the input pins.
Return Value:	1:HIGH, 0:LOW.

Syntax:	Get_gpo_status(int pin)
Description:	Get the status of GPIO output pins status.
Parameters:	This function fills in an integer variable as the parameter. The pin0 ~ pin3 is the status of the output pins.
Return Value:	1:HIGH, 0:LOW.

Syntax:	Set_gpo(int pin, int value)
Description:	Set the status of GPIO Output value.
Parameters:	Set value 0 is Low, 1 is High
Return Value:	If the function sets the values successfully, it returns 0 or -1, any other returned value stands for error.

4.3.2. Watchdog

Syntax:	Void wdt_start(int _timevalue)
Description:	This function gets the watchdog timer register to the time value and starts to count down.
Parameters:	The parameter 'val' is the value to set to watchdog timer register. The range is 1 ~ 255.
Return Value:	This function returns the value of the time counter and returns it to the caller as an unsigned integer.

Syntax:	Int get_wdt_count(void)
Description:	This function reads the value of the watchdog time counter.
Parameters:	None.
Return Value:	This function returns the value of the time counter.

Syntax:	Void wdt_stop(void)
Description:	This function sets the watchdog timer stop.
Parameters:	None.
Return Value:	None.

4.3.3. LCD Control Module

Syntax:	Void clear_lcm_display(void)
Description:	Clear the screen of the LCM.
Parameters:	None.
Return Value:	None.

Syntax:	Void graphicwritelcm (unsigned char *data)
Description:	Graphci Lcm show display function
Parameters:	unsigned char pointer 512bytes pointe hex
Return Value:	None.

Syntax:	Void get_lcm_mode_type(unsigned char *data)
Description:	This function can get lcm type mode
Parameters:	unsigned char pointer 10bytes data, the lcm type mode will save to pointer data.
Return Value:	None.

Syntax:	int get_lcm_key_code(unsigned char *data)
Description:	Scan the LCM and return the identification of the pressed direction key.
Parameters:	unsigned char pointer one byte, the key code will save to pointer data.
Return Value:	'0: Success -1:Fail The pointer data : 0x1E is Center key 0x1D is Up key 0x1B is Right key 0x17 is Left key 0x0F is Down key

Syntax:	void set_lcm_displayoff(void)
Description:	This function can turn off lcm display.
Parameters:	None.
Return Value:	None.

Syntax:	Void set_lcm_displayon(void)
Description:	This function can turn on lcm display.
Parameters:	None.
Return Value:	None.

Syntax:	Void get_lcm_firmware_ver(unsigned char *data)
Description:	This function can get LCM PIC Version.
Parameters:	lcm pic version will save the unsigned char pointer parameters.
Return Value:	None.

4.3.4. Power Supply Unit (PMBUS)

Syntax:	float pmbus_read_vout_12V(void)
Description:	This function can get power supply unit Vout 12V.
Parameters:	None.
Return Value:	float Vout 12V

Syntax:	float pmbus_read_vout_3V3(void)
Description:	This function can get power supply unit Vout 3.3V.
Parameters:	None.
Return Value:	float Vout 3.3V

Syntax:	float pmbus_read_vout_5V(void)
Description:	This function can get power supply unit Vout 5V.
Parameters:	None.
Return Value:	float Vout 5V

Syntax:	int get_pmbus_psu_status(int psu)
Description:	This function can get which power supply unit status.
Parameters:	psu: 0-1
Return Value:	0: Good, 1: Fail

4.3.5. Pmbus Command Code Summary

Support Command Code Table:

Command Code	Command Name	Data Format	Number of Data Bytes
03h	CLEAR_FAULTS(1)	Send Byte	0
20h	VOUT_MODE	Read Byte	1
79h	STATUS_WORD	Read Word	2
7Ah	STATUS_VOUT	Read Byte	1
7Bh	STATUS_IOUT	Read Byte	1
7Dh	STATUS_TEMPERATURE	Read Byte	1
80h	STATUS_OF_3V3 And 5V	Read Byte	1
8Bh	READ_+12V_VOUT	Read VOUT Mode	2
8Ch	READ_+12V_IOUT	Read Linear	2
8Dh	READ_TEMPERATURE_1 (2)	Read Linear	2
96h	READ_+12V_POUT	Read Linear	2
99h	MFR_ID	Read ASCII	6
9Ah	MFR_MODEL	Read ASCII	13
9Bh	MFR_REVISION	Read ASCII	2
9Eh	MFR_SERIAL	Read ASCII	12
A7h	MFR_POUT_MAX	Read Linear	2
A8h	MFR_TAMBIENT_MAX	Read Linear	2
B0h	PSU_STATUS	Read Byte	1
D1h	READ_TOTAL_POUT (3)	Read Linear	2
D2h	READ_3V3_VOUT	Read VOUT Mode	2
D3h	READ_3V3_IOUT	Read Linear	2
D4h	READ_3V3_POUT	Read Linear	2
D5h	READ_5V_VOUT	Read VOUT Mode	2
D6h	READ_5V_IOUT	Read Linear	2
D7h	READ_5V_POUT	Read Linear	2

Command Code	Command Name	Data Format	Number of Data Bytes
FBh	Buzzer_Mute (4)	R/W Byte	1

Note 1: Status will retain the last occurrence. Latch defined as the status. Must be cleared through the 03h (CLEAR_FAULTS) command. Please See the following Table.

Command	Status Name	Status action
79h	STATUS_WORD	Latch
7Ah	STATUS_VOUT	Latch
7Bh	STATUS_IOUT	Latch
7Dh	STATUS_TEMPERATURE	Latch
80h	STATUS_OF_3V3 And 5V	Latch
B0h	PSU_STATUS	Automatic recovery

Note 2: READ_TEMPERATURE_1 should provide the PDB Inlet Ambient temperature.

Note 3: Read Total Power command only at +12 V, 3V3, 5V total power.

Note 4: Buzzer will alert when any PSU fault occurs. Write 0x20 command in PMBus will be able to mute buzzer alarm. When PSU goes back to normal state, the register will be set at 0x00.

Contents in 20h (VOUT_MODE) Command Code:

Mode	Bits [7:5]	Bits [4:0] (Parameter)
Linear	000b	Five bit two's complement exponent for the mantissa delivered as the data bytes for an output voltage related command.

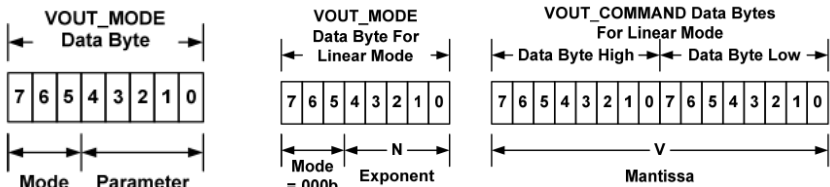

Note: The Mode bits are set to 000b.
 The Voltage (ex. +12V_VOUT, 3V3_VOUT, 5V_VOUT), in volts, is calculated from the equation: **Voltage = V x 2^N**
 Where:
 Voltage is the parameter of interest in volts;
 V is a 16 bit unsigned binary integer; and
 N is a 5 bit two's complement binary integer.

Contents in 79h (STATUS_WORD) Command Code:

Byte	Bit Number	Status Bit Name	Meaning
Low	[7:0]	Reserved	Return=0
High	7	VOUT	+12V Output voltage warning has occurred = 1 ; Normal = 0
High	6	IOUT	+12V Output current warning has occurred = 1 ; Normal = 0
High	5	Reserved	Return=0
High	4	3V3/5V_VOUT&IOUT	3V3/5V Output voltage warning has occurred =1 ; Normal = 0
High	3	POWER_GOOD#	The POWER_GOOD signal is OK = 1 ; FAIL = 0
High	[2:0]	Reserved	Return=0

Contents in 7Ah (STATUS_VOUT) Command Code:

Bit Number	Status Bit Name	Meaning
7	Reserved	Return=0
6	+12V_OV_WARNING	VOUT > 13.0V = 1 ; Normal = 0
5	+12V_UV_WARNING	VOUT < 11.0V = 1 ; Normal = 0
[4:0]	Reserved	Return=0

Contents in 7Bh (STATUS_IOUT) Command Code:

Bit Number	Status Bit Name	Meaning
[7:6]	Reserved	Return=0
5	+12V_OC_WARNING	+12V_IOUT > Max Current of 110%@1Sec = 1 ; Normal = 0
[4:0]	Reserved	Return=0

Contents in 7Dh (STATUS_TEMPERATURE) Command Code:

Bit Number	Status Bit Name	Meaning
[7:3]	Reserved	Return=0
3	AMBIENT_OT_FAULT	Ambient temperature >60°C = 1 ; Normal =0
2	AMBIENT_OT_WARNING	Ambient temperature >55°C = 1 ; Normal = 0
[1:0]	Reserved	Return=0

Contents in 80h (STATUS_OF_3V3 And 5V) Command Code:

Bit Number	Status Bit Name	Meaning
------------	-----------------	---------

7	5V_OC_FAULT	5V_IOUT > Max Current of 130%@ 1Sec = 1 ; Normal = 0
6	3V3_OC_FAULT	3V3_IOUT > Max Current of 130%@ 1Sec = 1 ; Normal = 0
5	5V_UV_WARNING	VOUT < 4.5V = 1 ; Normal = 0
4	3V3_UV_WARNING	VOUT < 3.0V = 1 ; Normal = 0
3	5V_OV_WARNING	VOUT > 5.5V = 1 ; Normal = 0
2	5V_OC_WARNING	5V_IOUT > Max Current of 110%@ 1Sec = 1 ; Normal = 0
1	3V3_OV_WARNING	VOUT > 3.6V = 1 ; Normal = 0
0	3V3_OC_WARNING	3V3_IOUT > Max Current of 110%@ 1Sec = 1 ; Normal = 0

Contents in B0h (PSU_STATUS) Command Code:

Bit Number	Status Bit Name	Meaning
[7:4]	Reserved	Return=0
3	PSU2 PRESENT	Module Plug OUT = 1 ; Module Plug IN = 0
2	PSU1 PRESENT	Module Plug OUT = 1 ; Module Plug IN = 0
1	PSU2 STATUS	FAIL = 1 ; OK = 0
0	PSU1 STATUS	FAIL = 1 ; OK = 0

MFR Meaning:

Command Code	Command Name	Meaning
99h	MFR_ID	ETASIS
9Ah	MFR_MODEL	EFRP-S2287HPM
9Bh	MFR_REVISION	A0 ~ Z9
9Eh	MFR_SERIAL	Code = 12 (ex. T201XXG00001)
A7h	MFR_POUT_MAX	280 (W)
A8h	MFR_TAMBIENT_MAX	40 (°C)

I²C Address Set Table:

PDB MCU Device	4A
FRU Device (Option)	AC

4.3.6. Chassis Opened

Syntax:	int get_chassis_open_status(void)
Description:	This function can get chassis status.
Parameters:	None.
Return Value:	0: Disabled, 1: Enabled.

Syntax:	void set_chassis_open(int value)
Description:	This function can set chassis opened.
Parameters:	0: Disabled, 1: Enabled.
Return Value:	None.

4.3.7. Notes

Syntax:	int libw83627_init(void)
Description:	use the watchdog, gpio function before, must be call this function first.
Parameters:	None.
Return Value:	0: Successful, -1: Fail

Syntax:	void lib_close(void)
Description:	if library not use on your program, please call this function.
Parameters:	None.
Return Value:	None.

5. FAQ

Q 1. *Where can I find the serial number of this product?*

- The serial number (S/N) is a label printed with alpha-numeric character. You can find the S/N label on the bottom of this product or on its packing box.

Technical Support Form

We deeply appreciate your purchase of Acrosser products. Please find the “**tech_form.doc**” file in our utility CD. If you have any questions or problems about Acrosser products, please fill in the following information. We will answer your questions in the shortest time possible.

Describe Your Info and Acrosser System Info

- Your Company Name: _____
- Your Contact Info: _____ Phone Number: _____
- Your E-Mail Address: _____
- Your Company Address: _____

- Acrosser Model Name: _____
- Acrosser Serial Number: _____

Describe System Configuration

- CPU Type: _____
- Memory Size: _____
- Storage Device (e.g. HDD, CF, or SSD): _____
- Additional Peripherals (e.g. Graphic Card): _____
- Operating System & Version (e.g. Windows 7 Embedded): _____
- Special API or Driver: _____
(If yes, please provide it for debug.)
- Running Applications: _____
- Others: _____

Describe Your Problems or Questions:

Send the above information to one of the following Acrosser contacts:

- Acrosser Local Sales Representative
- Acrosser Authorized Sales Channels
- Acrosser Inquiry --- <http://www.acrosser.com/inquiry.html>
- Acrosser FAX Number --- 886-2-29992887

To Make Your
Embedded
Idea a Reality

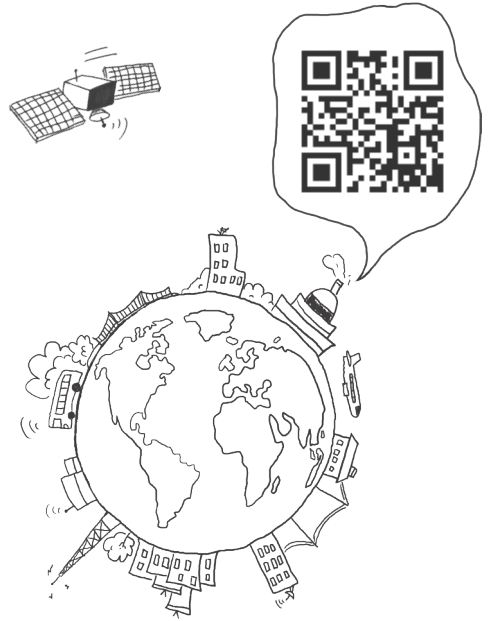

Acrosser Headquarters

241新北市三重區光復路一段61巷26號10樓
10F., No.26, Ln. 61, Sec. 1, Guangfu Rd.,
Sanchong Dist., New Taipei City 241, Taiwan
(R.O.C.)

TEL: +886-2-29999000

FAX: +886-2-29992887 / +886-2-29993960

Acrosser Taichung Office

414台中市烏日區僑仁街8號10樓之1
10F.-1, No.8, Qiaoren St., Wuri Dist.,
Taichung City 414, Taiwan (R.O.C.)

TEL: +886-4-2337-0715

FAX: +886-4-2337-3422

Acrosser China Subsidiary

深圳市欣扬通电子有限公司
深圳市福田区泰然八路安华工业区6号楼7层
706室 (邮编: 518040)

Room 706, floor 7, building 6, Anhua Industrial
Zone, Tairan 8th Road, Futian District, Shenzhen,
China (Postal: 518040)

TEL: +86-755-83542210

FAX: +86-755-83700087

Acrosser Nanjing Office

欣扬通电子有限公司 南京办事处
江苏省南京市江宁区天元东路228号504室
(邮编: 211100)

Room 504, No. 228, Tian Yuan East Rd.,
Jiang Ning Dist., Nanjing City, Jiangsu Province,
China (Postal: 211100)

Mobile: 13611932003

TEL: +86-025-86137002

FAX: +86-025-86137003

Acrosser Beijing Office

欣扬通电子有限公司 北京办事处
北京市昌平区沙河镇沙阳路巩华新村8号楼2单元
1403室 (邮编: 102206)

Room 1403, Unit 2, Building 8, Gonghua Village,
Shahe Town, Changping District, Beijing, China
(Postal: 102206)

Mobile: 13311317329

Acrosser USA Inc.

8351 Elm Ave. Suite 107, Rancho Cucamonga,
CA91730, USA

TEL: +1-909-476-0071

FAX: +1-909-466-9951